



Lato Angolo

apertura ad ante scorrevoli, una fissa e una apribile.

Accès d'angle à quatre panneaux, un côté

ouverture par deux panneaux coulissants sur deux panneaux fixes.

Corner shower enclosure (one side)

opening with sliding panels, two fixed and two can be opened.

Angular de dos hojas correderas (un lado)

con dos hojas fijas y dos correderas.

2-tlg. Eckeinstieg (eine Seite)

mit zwei festen Wänden und zwei Schiebetüren.

Hoekinstap met vier panelen, een zijde

met twee schuivende panelen en twee vaste panelen.

Четырехстворчатая угловая конструкция (одна

сторона) открытие при помощи раздвижных створок: две стационарные и две открывающиеся.

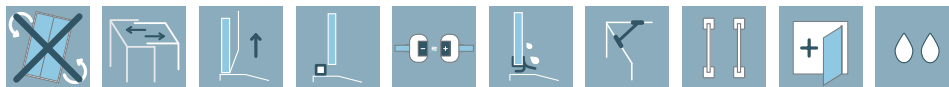

H 195 cm. - V 6 mm.

Finitura profili

Finitions des profilés
Profiles finishing
Acabado perfiles
Profilfarbe
Profiel afwerkingen
Отделка профилей



ULU
brillantato cromo
chromé brillant
brilliant chrome
aluminio cromo
Chrom glänzend
glanzend chrom
светлый блестящий хром



SNK
Nickel satinato
Nickel satiné
Satinéd nickel
Niquel satinado
Nickel satiniert
Gesatineerd nikkel
Атласный никель



ELO
Alluminio oro
Aluminium or
Gold aluminium
Aluminio oro
Gold Aluminium
Goud aluminium
Алюминиевая золото



AL4
Alluminio bronzo
Aluminium bronze
Bronze aluminium
Aluminio bronze
Bronze AluminiumB
rons aluminium
Алюминиевая бронза



AL5
Alluminio oro rosato
Aluminium or rose
Pink gold aluminium
Aluminio oro rosa
Rotgold Aluminium
Roségoud aluminium
Алюминий розовое золото



AL6
Alluminio nero
Aluminium noir
Black aluminium
Aluminio negro
Schwarzes Aluminium
Zwart aluminium
Черный алюминий



TR
trasparente
transparent
transparent
transparente
Klarglas
transparent
прозрачное

Finitura pannelli

Finitions des panneaux
Panels finishing
Acabado perfiles
Glasart
Paneel afwerkingen
Отделка панелей

Lato Angolo

Accès d'angle à quatre panneaux (un côté)



Corner shower enclosure (one side)

Angular de dos hojas correderas (un lado)

2-tlg. Eckeinstieg (eine Seite)

Hoekinstap met vier panelen (een zijde)

Четырехстворчатая угловая конструкция (одна сторона)



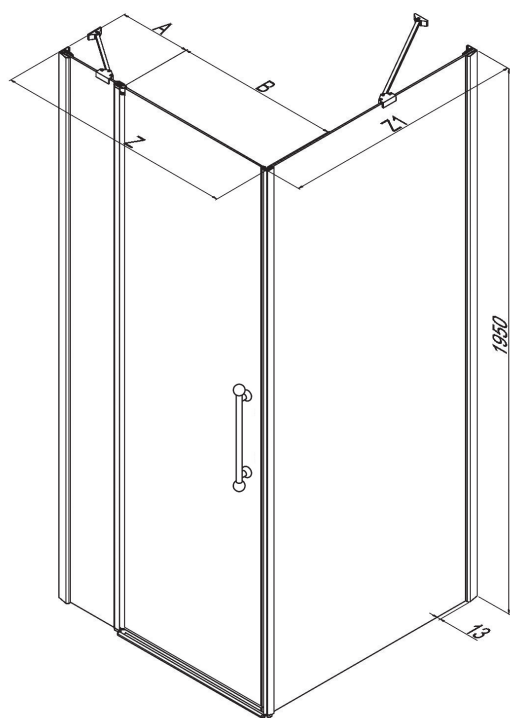





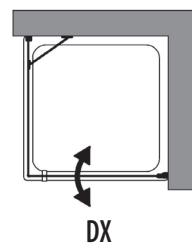
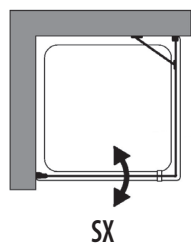
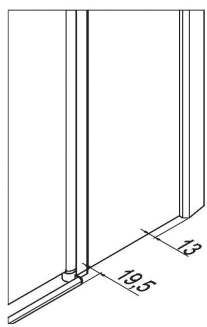
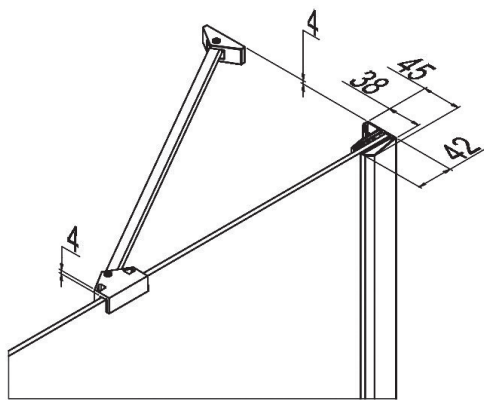
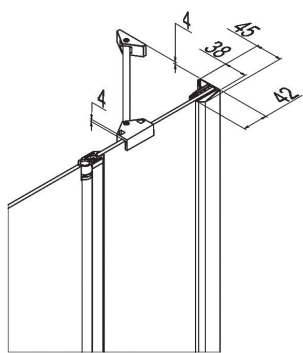
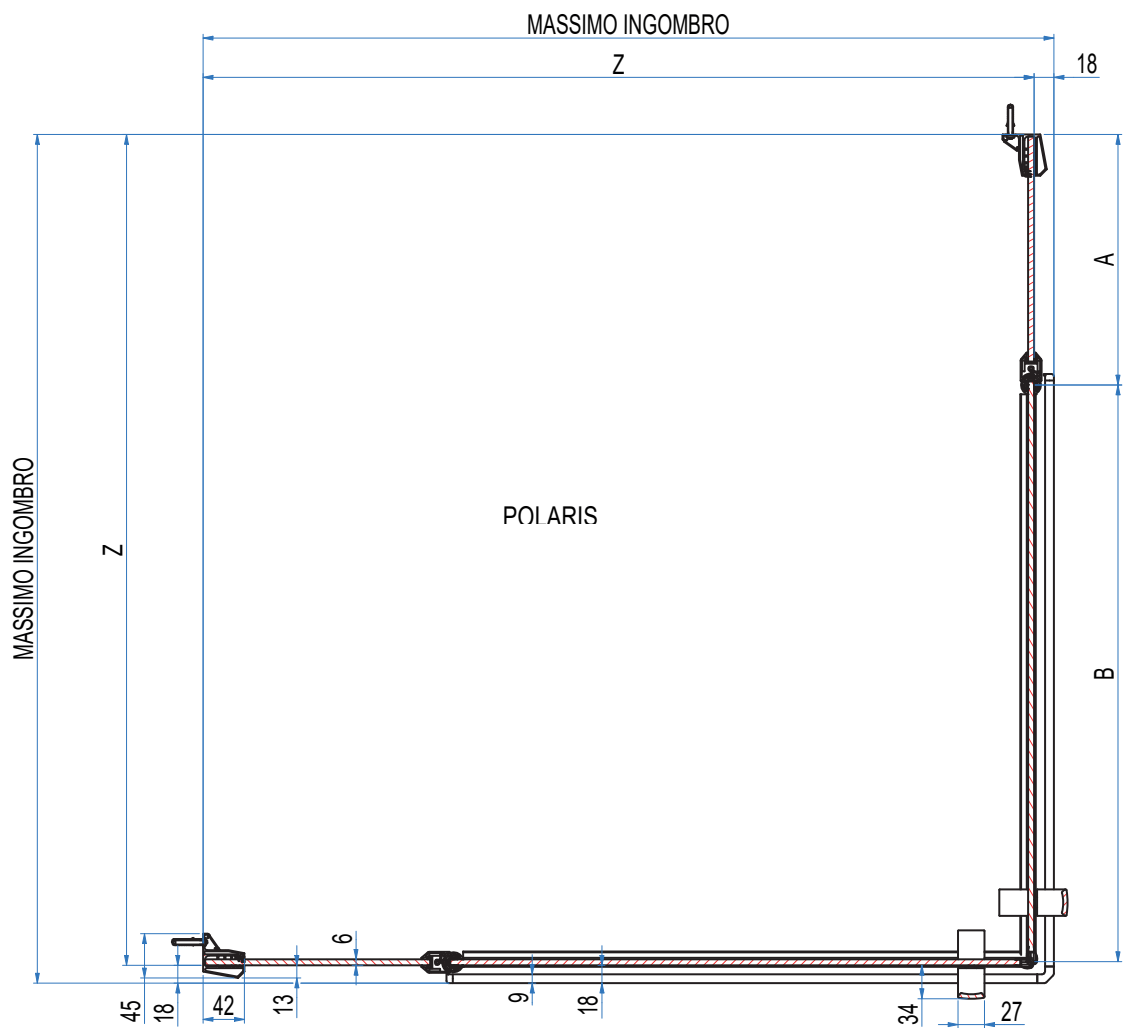



Articolo	Estensibilità Z [cm]	Massimo ingombro Z + 1,8 [cm]	A [cm]	B [cm]	C [cm]	 [dm³]	 [kg]	 [n°]
B0204	76,5-79	77,3-80,8	//	//	85	102	24	1
B0205	79-81,5	80,8-83,3	//	//	88	106	24	1
B0207	85-87,5	86,8-89,3	//	//	91	114	25	1
B0208	87,5-90	89,3-91,8	//	//	93	117	26	1
B0210	95-97,5	96,8-99,3	//	//	96	118	28	1
B0211	97,5-100	99,3-101,8	//	//	99	146	32	1
B0213	115-117,5	116,8-119,3	//	//	127	175	38	1



320 mm

Interasse maniglia
Empattement de la poignée
Handle wheelbase
Distancia entre ejes de la manija
Radstand handhaben
Handvat wielbasis
Колесная база ручки



Prodotti Speciali - Produits Spéciaux - Special products - Productos Especiales - Sonderfertigungen - Maatwerk - Специальные Иродукты									
1	MISURE LIMITE	Altezza max 217 cm.	//	Larghezza max 120 cm.	Larghezza min 65 cm.				
2	MESURES LIMITES	Hauteur max 217 cm.	//	Largeur max 120 cm.	Largeur min 65 cm.				
3	LIMITS OF MEASUREMENTS	Height max 217 cm.	//	Width max 120 cm.	Width min 65 cm.				
4	MEDIDAS LIMITE	Altura max 217 cm.	//	Anchura max 120 cm.	Anchura min 65 cm.				
5	GRENZMAßE	Höhe max 217 cm.	//	Breite max 120 cm.	Breite min 65 cm.				
6	EXTREME MATEN	Hoogte max 217 cm.	//	Breedte max 120 cm.	Breedte min 65 cm.				
7	ПРЕДЕЛЬНЫЕ РАЗМЕРЫ:	Макс. высота 217 см	//	Макс. ширина 120 см	Мин. ширина 65 см				
8		I							
9		II							
10		III							
11									

Maniglia optional solo su richiesta, 1 pezzo - Ручка, не входящая в комплект стандартной поставки, поставляется по отдельному заказу, одна штука.
Poignée optionnelle seulement sur demande, 1 pièce - Optional handle only on request, 1 piece

N00 CRO_SNK_SL4_AL5_AL6_ELO



M00 CRO_SNK_SL4_AL5_AL6_ELO



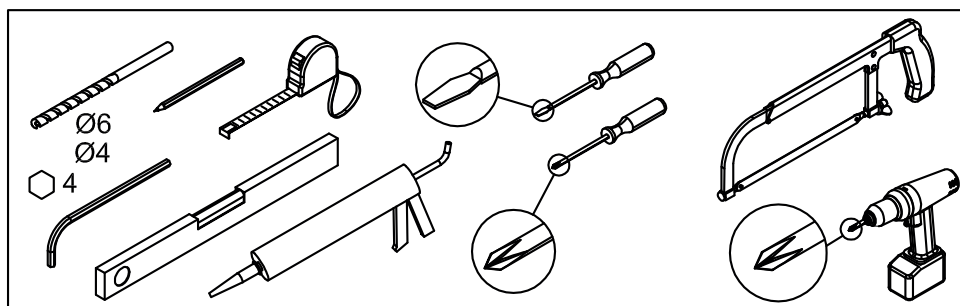
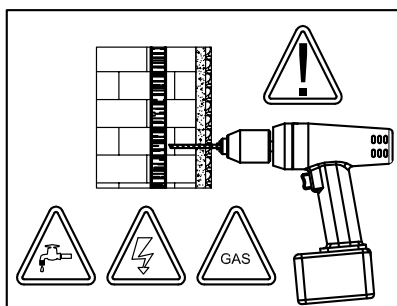
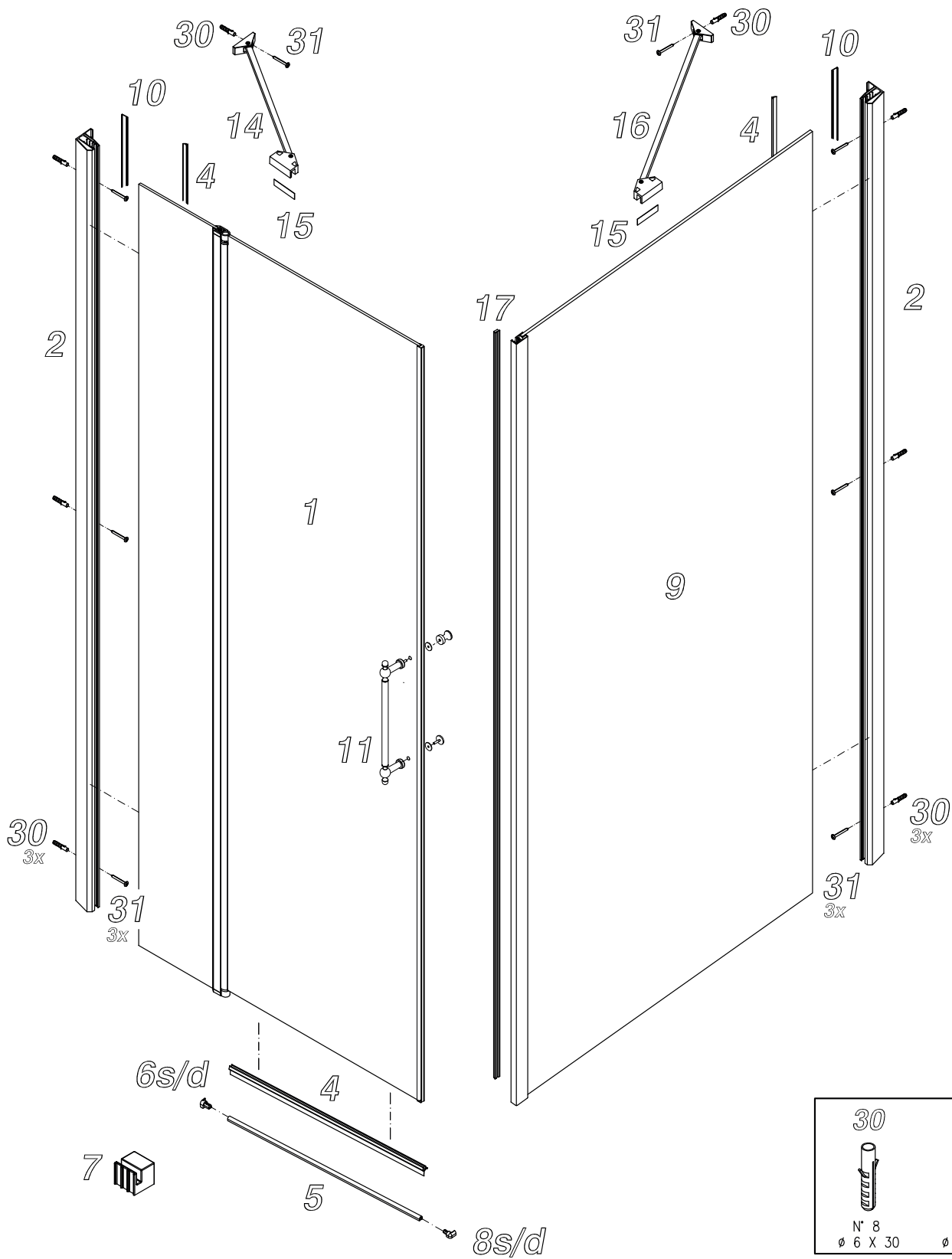

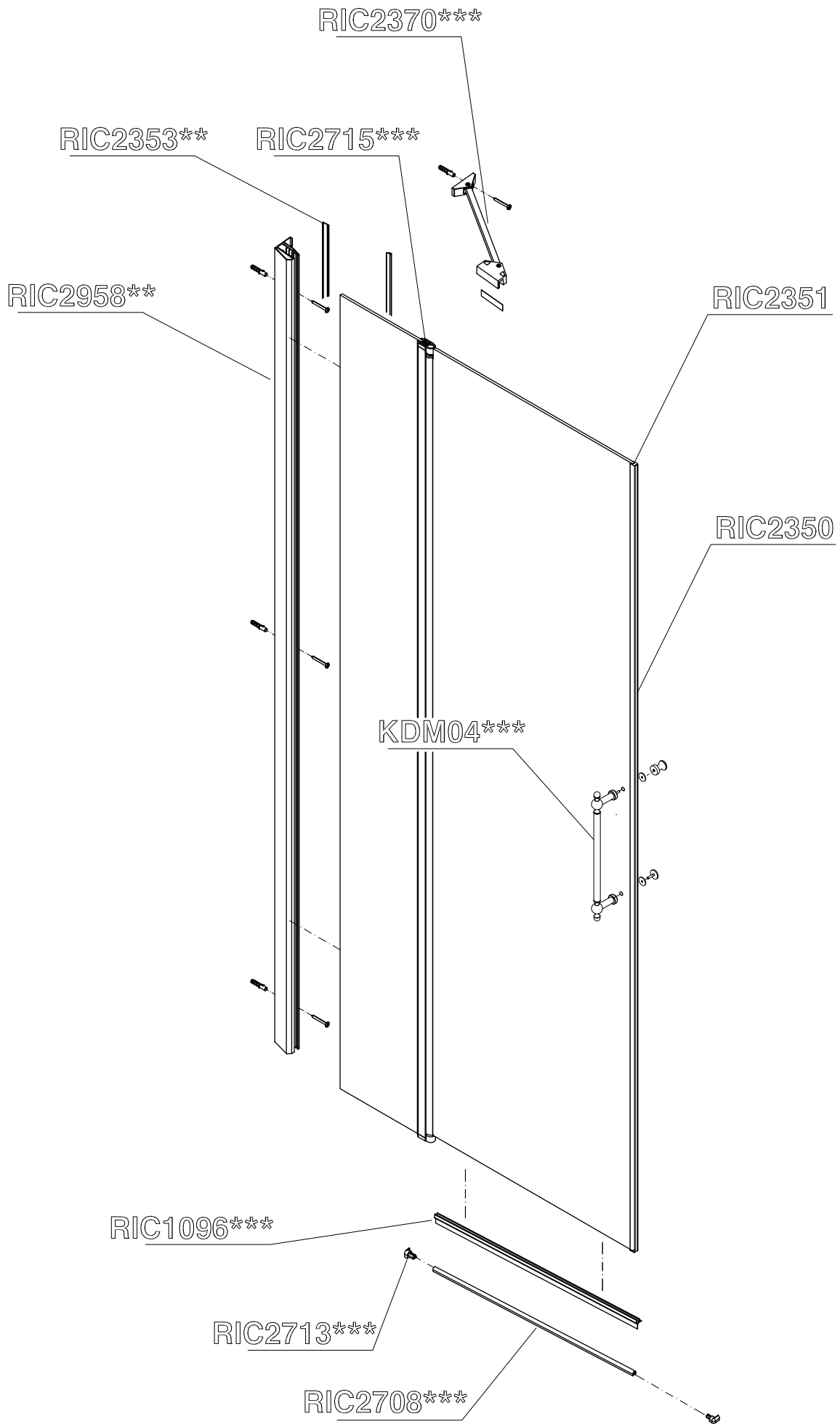

<p>RIC2958***</p> <p>2 mt</p> <p>1x</p> <p>1x</p>	<p>RIC2353**</p> <p>1x</p>	<p>RIC2352</p> <p>2 mt</p>	<p>RIC 2747</p>
<p>RIC2708***</p> <p>1x</p>		<p>RIC2350</p> <p>1x</p>	<p>RIC1096***</p> <p>1x</p>
<p>RIC1799</p> <p>6x</p> <p>4x</p> <p>6x</p> <p>4x</p>	<p>RIC2713***</p> <p>1x</p> <p>1x</p> <p>1x</p> <p>1x</p>	<p>RIC2370***</p> <p>1x</p> <p>1x</p> <p>1x</p>	
<p>RIC2351</p> <p>1x (sx)</p> <p>1x (dx)</p> <p>2x</p>	<p>KDM04***</p> <p>1x</p>	<p>RIC2715***</p> <p>1x (sx)</p> <p>1x (dx)</p> <p>2x</p> <p>TP 3,5 x 32</p> <p>2x</p> <p>1x</p> <p>1x</p>	